

DIASTEREOSPECIFIC SYNTHESIS OF DIAZIRIDINES FROM D-MANNITOL.
 ACCESS TO CHIRAL α -AMINOACIDS.

A. Duréault, C. Greck and J.C. Depezay *

Université René Descartes - Laboratoire de Chimie et Biochimie
 Pharmacologiques et Toxicologiques (Unité Associée au CNRS n°400)
 45 rue des Saints Pères - 75270 Paris Cédex 06, FRANCE.

Abstract : Nucleophilic opening of chiral diastereoisomeric diaziridines obtained from D- mannitol leads to precursors of D or L α -aminoacids (or aldehydes) and also provides a means of synthesizing polyhydroxylated piperidines.

Many non classical α -aminoacids exhibit high biological activity. Therefore new methods for their synthesis ¹ could prove very useful. The preparation of suitably protected, optically pure α -aminoaldehydes as chiral educts for asymmetric products has also attracted a great deal of interest ². Since N-protected aziridines can be aminoalkylating agents for a variety of nucleophiles and especially for organometallic compounds ³, chiral, suitably functionalised aziridines can be precursors of enantiomerically pure α -aminoacids or aldehydes. The methodology we propose (scheme I) is similar to the one we have recently published concerning the synthesis of chiral α -hydroxyaldehydes ⁴.

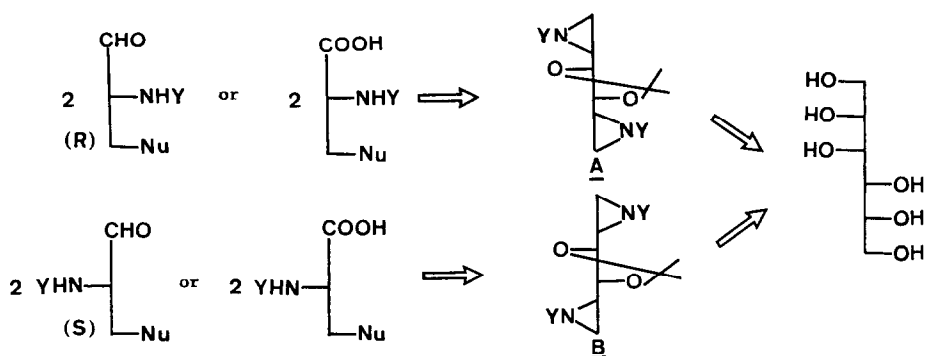

Scheme I

This note describes the synthesis of the two functionalised diastereoisomeric diaziridines A and B from D-mannitol, with various nitrogen protecting or activating groups and presents, in order to check the validity of the proposed scheme, an example of nucleophilic opening of these aziridines followed by oxidative cleavage leading to α -aminoacids.

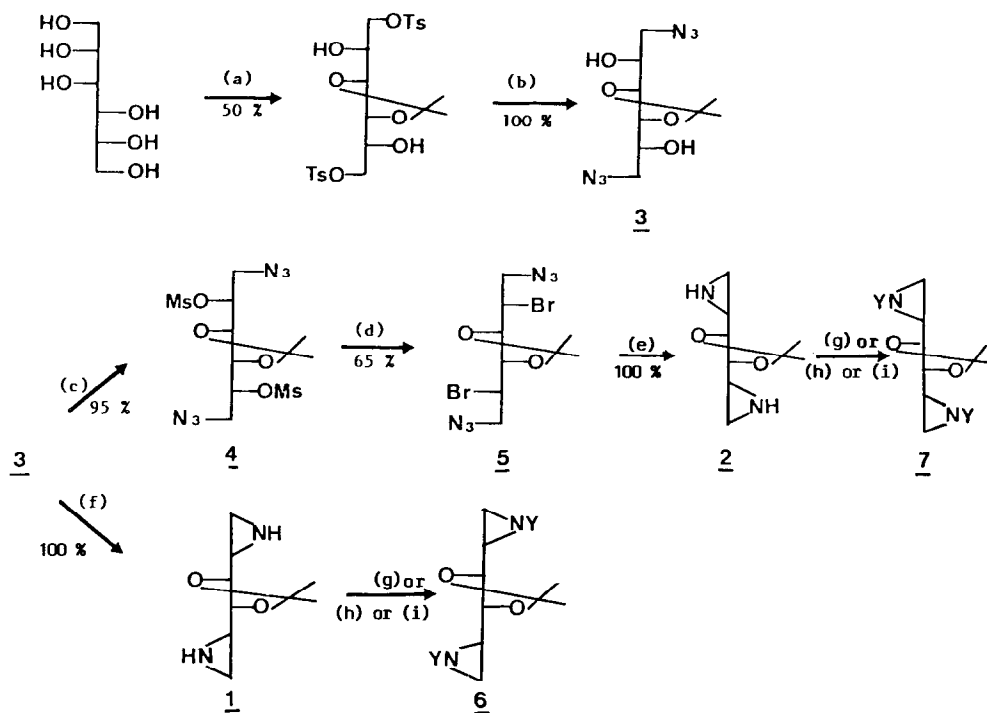

Scheme II *

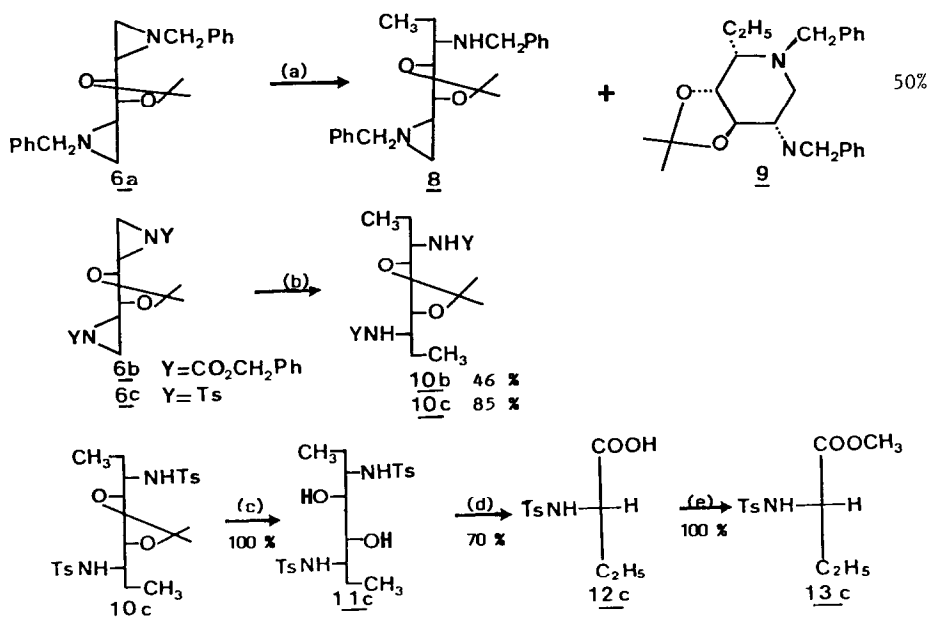

Scheme III **

Diaziridines prepared from D-mannitol are 1,2 : 5,6 diimino 3,4-O-methylethylidene hexane diols 2S, 3R, 4R, 5S, 1 and 2R, 3R, 4R, 5R 2. They are obtained with 100 % and 60 % yield respectively from diazido diol 3, itself formed with 50 % yield from D-mannitol.

Diaziridine 1 results from reductive ring closure of 3 by triphenylphosphine with configuration inversion at C-2 and C-5⁵ (complete ring closure occurs after twenty hours heating in refluxing toluene). Diaziridine 2 results from reduction of the diazido dibromo compound 5 by lithium aluminium hydride. This reaction involves cyclisation and configuration inversion⁶. 5 has been formed through dimesylation of 3 into 4 and nucleophilic substitution by bromide ions (MgBr_2) with inversion at C-2 and C-5 of 4⁷.

In order to effect the following steps (nucleophilic opening - cleavage) the N-unsubstituted raw diaziridines 1 and 2 were transformed into the appropriate N-protected aziridines 6a, b, c, and 7a, b, c, respectively (a $\text{Y}=\text{CH}_2\text{Ph}$; b $\text{Y}=\text{COCH}_2\text{Ph}$; c $\text{Y}=\text{Ts}$)¹⁰.

Regiospecific ring-opening addition of dimethylcopperlithium to N-benzyl diaziridine 6a promoted by BF_3 -etherate leads to monoalkylated derivative 8 and to the chiral 3-amino-4,5-dihydroxy piperidine 9 with four asymmetric carbons of known configuration. Synthesis of analogues of 9 (using other nucleophiles) is attractive since polyhydroxylated piperidines have recently been shown to be a powerful set of inhibitors of glycosidase activity⁸. Nucleophilic opening of the first aziridine ring leading to a non stabilised metallic amide, is followed by heterocyclisation due to attack of the amide at the C-6 of the second aziridine cycle.

When $\text{Y}=\text{COCH}_2\text{Ph}$ or Ts, nucleophilic ring opening addition of 6b or 6c by dimethylcopperlithium in THF (without Lewis acid catalysis), leads to diamines 10b or 10c in 46 % or 85 % yield respectively¹⁰. In both cases attack occurs at the less hindered carbons. The N-tosyldiaziridine 6c was found as expected to be a more reactive substrate than diaziridine 6b. Since some benzylic alcohol is recovered in the reaction, the poorest yield in case of 6b can be due either to partial decomposition of the intermediate metallic amide, or to intermolecular metallic amide attack at the carbonyl group of the aziridine carbamate. The acetonide 10c was hydrolysed and oxydative cleavage of the resulting diol 11c led to tosyl L- α -aminobutyric acid. The specific rotation of its methyl ester 13c compares well with previously reported results (13c : -26° , lit. -22° ⁹).

Diastereoisomeric N-Tosyl diaziridines prepared from D-mannitol are interesting precursors for the synthesis of enantiomerically pure α -aminoacids. By extension of the results reported herein, the use of N-benzyl diaziridines provides a promising approach to the synthesis of chiral polyhydroxylated amino piperidines.

oOo

* (a) ref.4 ; (b) NaN_3 , DMF, 70°C , 3h.; (c) MsCl , Py, 20°C , 20h.; (d) MgBr_2 , CH_2Cl_2 -ether, 40°C , 20h. ; (e) LiAlH_4 , THF, 20°C , 6h. ; (f) PPh_3 , toluène, 105°C , 20h. ; (g) PhCH_2Br , NEt_3 , THF, 20°C , 15h., 70% ; (h) PhCH_2COCl , NEt_3 , CH_2Cl_2 , 20°C , 60% ; (i) 1-KH, THF, 20°C 2-TsCl, 20°C , 55%.

** (a) Me_2CuLi , $\text{BF}_3 \cdot \text{Et}_2\text{O}$ 5eq. THF $-78^\circ\text{C} \rightarrow +20^\circ\text{C}$; (b) Me_2CuLi , 2eq. THF $-78^\circ\text{C} \rightarrow -30^\circ\text{C}$; (c) CF_3COOH , H_2O , 0°C , 4h. ; (d) CrO_3 , NaIO_4 , AcOH , H_2O , 20°C , 4h. ; (e) CH_2N_2 , ether.

References and notes :

- a) Reviews: J.W. Apsimon and R.P. Seguin, *Tetrahedron*, 1979, 35, 2797.
D. Hoppe, *Nachr. Chem. Techn. Lab.*, 1982, 30, 783 - U. Schöllkopf in "Topics in current chemistry", 1983, 109, 65,.
- b) P.J. Maurer, M. Takahata and H. Rapoport, *J. Am. Chem. Soc.*, 1984, 106, 1095 - J.M. Fitzner, R.G. Shea, J.E. Fankhauser, P.B. Hopkins, *J. Org. Chem.*, 1985, 50, 419 - J.A. Bajgrowicz, A. El Hallaoui, R. Jacquier, Ch. Pigière, Ph. Viallefont, *Tetrahedron*, 1985, 41, 1833.
W. Oppolzer, R. Pedrosa and R. Moretti, *Tetrahedron Lett.*, 1986, 27, 831
- a) J.A. Ferentz and B. Castro, *synthesis*, 1983, 676.
- b) Review: D. Tourwé, *Janssen Chimica Acta*, 1985, 3, 3.
- a) O.C. Dermer, G.E. Heem, "Ethyleneimine and other aziridines" Academic Press, N.Y. 1969.
- b) A.P. Kozikowski, H. Ishida and K. Isobe, *J. Org. Chem.*, 1979, 44, 2788 - M.J. Eis and B. Ganem, *Tetrahedron Lett.*, 1985, 26, 1153 - M. Aratani, L.V. Dunkerton, T. Fukuyama, Y. Kishi, H. Kakoi, S. Sugiura, S. Inoue, *J. Org. Chem.*, 1975, 40, 2009.
- Y. Le Merrer, A. Duréault, C. Gravier, D. Languin and J.C. Depezay, *Tetrahedron Lett.*, 1985, 26, 319.
- Y. Ittah, Y. Sasson, I. Shahak, S. Isaroom and J. Blum, *J. Org. Chem.*, 1978, 43, 4271.
- J.N. Denis, A. Krief, *Tetrahedron*, 1979, 35, 2901.
- P. Place, M.L. Roumestant, J. Gore, *Bull. Soc. Chim. France*, 1976, 169.
- a) Lalegerie, G. Legler and J.M. Yon, *Biochimie*, 1982, 64, 977 - G.W. Fleet, P.W. Smith, S.V. Evans and L.E. Fellows, *J. Chem. Soc. Chem. Commun.*, 1984, 1240 and references cited therein S.V. Evans, A.R. Hayman, L.E. Fellows, T.K.M. Shing, A.E. Derome and G.W. Fleet, *Tetrahedron Lett.*, 1985, 26, 1465 and references cited therein - R.C. Bernotas and B. Ganem, *Tetrahedron Lett.*, 1985, 26, 4981 - M.J. Eis, C.J. Rule, B.A. Wurzburg and B. Ganem, *Tetrahedron Lett.*, 1985, 26, 5397.
- J.A. Bajgrowicz, A. El Hallaoui, R. Jacquier, Ch. Pigière, Ph. Viallefont, *Tetrahedron Lett.*, 1984, 25, 2759.
- Yields given on scheme II and III correspond to purified products (recrystallization or flash chromatography). ¹H NMR spectra (250 MHz, CDCl₃), analyses and/or mass spectra are consistent with the assigned structures. Specific rotation are taken for λ = 589nm, at 20°.
- $\frac{3}{4}$ $\left\{ \begin{array}{l} [\alpha] = + 47^\circ \text{ (C=1, 4, CH}_2\text{Cl}_2) \\ [\alpha] = + 3^\circ \text{ (C=1, CH}_2\text{Cl}_2) - \text{m.p.} = 91^\circ\text{C} \\ [\alpha] = + 41^\circ \text{ (C=1, CH}_2\text{Cl}_2) \end{array} \right.$
- $\frac{5}{6a}$ $\left\{ \begin{array}{l} [\alpha] = -45^\circ \text{ (C=1, CH}_2\text{Cl}_2) - \text{NMR : } 7,30-7,20 \text{ (m, 10H, arom.) ; } 3,55 \text{ (m, 2H, H}_3) \text{ ; } 3,41-3,30 \\ \text{(AB, J = 12,5 Hz, 4H, NCH}_2) \text{ ; } 1,90 \text{ (d, J}_{1,2} = 3,5 \text{ Hz, 2H, H}_1 \text{ trans) ; } 1,57 \text{ (m, 2H, H}_2) \text{ ; } \\ 1,40 \text{ (d, J}_{1,2} = 6,3 \text{ Hz, 2H, H}_1 \text{ cis) ; } 1,34 \text{ (s, 6H, C(CH}_3)_2) \end{array} \right.$
- $\frac{6b}{5c}$ $\left\{ \begin{array}{l} [\alpha] = - 65^\circ \text{ (C=1, CH}_2\text{Cl}_2) - \text{m.p.} = 104^\circ\text{C} \\ [\alpha] = - 24^\circ \text{ (C=1, 5, CH}_2\text{Cl}_2) - \text{m.p.} = 60^\circ\text{C} - \text{NMR : } 7,82 \text{ (d, J = 8 Hz, 4H, arom.) ; } 7,35 \text{ (d, } \\ \text{4H, arom.) ; } 3,81 \text{ (m, 2H, H}_3) \text{ ; } 2,76 \text{ (m, 2H, H}_2) \text{ ; } 2,60 \text{ (d, J}_{1,2} = 7 \text{ Hz, 2H, H}_1 \text{ cis) ; } \\ 2,45 \text{ (s, 6H, CH}_3\text{-Ph) ; } 2,38 \text{ (d, J}_{1,2} = 5 \text{ Hz, 2H, H}_1 \text{ trans) ; } 1,23 \text{ (s, 6H, C(CH}_3)_2) \end{array} \right.$
- $\frac{7a}{7c}$ $\left\{ \begin{array}{l} [\alpha] = + 54^\circ \text{ (C=1, CH}_2\text{Cl}_2) - \text{NMR : } 7,33-7,25 \text{ (m, 10H, arom.) ; } 3,50 \text{ (m, 2H, H}_3) \text{ ; } 3,67- \\ 3,20 \text{ (AB, J = 13,5 Hz, 4H, NCH}_2) \text{ ; } 1,66 \text{ (d, J}_{1,2} = 3,5 \text{ Hz, 2H, H}_1 \text{ trans) ; } 1,6 \text{ (m, 2H, H}_2) \\ 1,39 \text{ (s, 6H, C(CH}_3)_2) \text{ ; } 1,34 \text{ (d, J}_{1,2} = 6,5 \text{ Hz, 2H, H}_1 \text{ cis).} \\ [\alpha] = + 42^\circ \text{ (C=2, 1, CH}_2\text{Cl}_2) - \text{m.p.} = 121^\circ\text{C} - \text{NMR : } 7,81 \text{ (d, J = 8,5 Hz, 4H, arom.) ; } 7,35 \\ \text{(d, 4H, arom.) ; } 3,62 \text{ (m, 2H, H}_3) \text{ ; } 2,90 \text{ (m, 2H, H}_2) \text{ ; } 2,61 \text{ (d, J}_{1,2} = 7 \text{ Hz, 2H, H}_1 \text{ cis) ; } \\ 2,43 \text{ (s, 6H, CH}_3\text{-Ph) ; } 2,25 \text{ (d, J}_{1,2} = 4,5 \text{ Hz, 2H, H}_1 \text{ trans) ; } 1,21 \text{ (s, 6H, C(CH}_3)_2) \\ \text{NMR : } 7,50-7,20 \text{ (m, 10H, arom.) ; } 3,84 \text{ (m, 2H, H}_4, \text{H}_5) \text{ ; } 3,88-3,65 \text{ (AB, J = 13 Hz, 2H, } \\ \text{NCH}_2) \text{ ; } 3,60-3,33' \text{ (AB, J = 13 Hz, 2H, NCH}_2) \text{ ; } 2,40 \text{ (m, 1H, H}_6) \text{ ; } 1,85-1,20 \text{ (m, 12H) ; } \\ 0,90 \text{ (dd, J = 7 Hz, 3H, CH}_3) \end{array} \right.$
- $\frac{0c}{1c}{3c}$ $\left\{ \begin{array}{l} [\alpha] = -62^\circ \text{ (C=1, CH}_2\text{Cl}_2) - \text{m.p.} = 198^\circ\text{C} \\ [\alpha] = -104^\circ \text{ (C=1, CH}_2\text{Cl}_2) - \text{m.p.} = 124^\circ\text{C} \\ [\alpha] = -26^\circ \text{ (C=0, 7, EtOH) - m.p.} = 68^\circ\text{C} - \text{NMR : } 7,75 \text{ (d, J = 8,5 Hz, 2H, arom.) ; } 7,26 \text{ (d, } \\ \text{2H, arom.) ; } 5,10 \text{ (d, J}_{2,\text{NH}} = 10 \text{ Hz, 1H, NH) ; } 3,87 \text{ (m, 1H, H}_2) \text{ ; } 3,50 \text{ (s, 3H, OCH}_3) \text{ ; } \\ 2,40 \text{ (s, 3H, PhCH}_3) \text{ ; } 1,76 \text{ (m, 1H, H}_3) \text{ ; } 1,68 \text{ (m, 1H, H}_3) \text{ ; } 0,92 \text{ (dd, J}_{3,4} = 7 \text{ Hz, J}_{3,4} = \\ 7,5 \text{ Hz, 3H, H}_4) \end{array} \right.$

(Received in France 29 May 1986)